

Unterflur Vollauszug mit Dämpfung/ Push-Open für Holzschubkästen

SLIDES FOR WOODEN DRAWERS, soft closing system/ push-open, undermount drawer slides, full extension

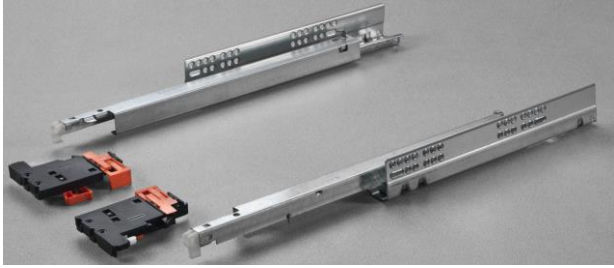

SALICE

FUTURA SMOVE/ PUSH

Abmessungen Schrankkorpus/ Schubkasten Dimensions cabinet/ Drawer

- SP = Zargendicke
- LN = Nennlänge der Führung/ nominal length drawer slides
- PM = Lichte Korpustiefe/ Inner cabinet depth
- X = Lichte Korpusbreite/ Inner cabinet width
- LC = Schubkastentiefe/ Drawer depth
- X - 41 mm = Lichte Schubkastenbreite/ Inner drawer width

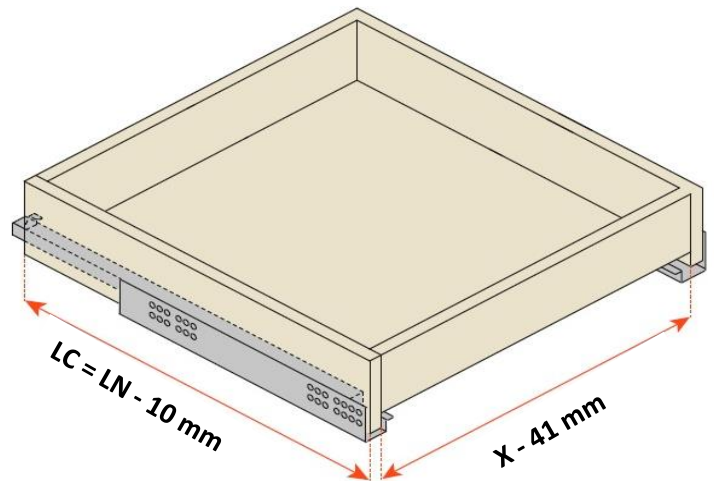
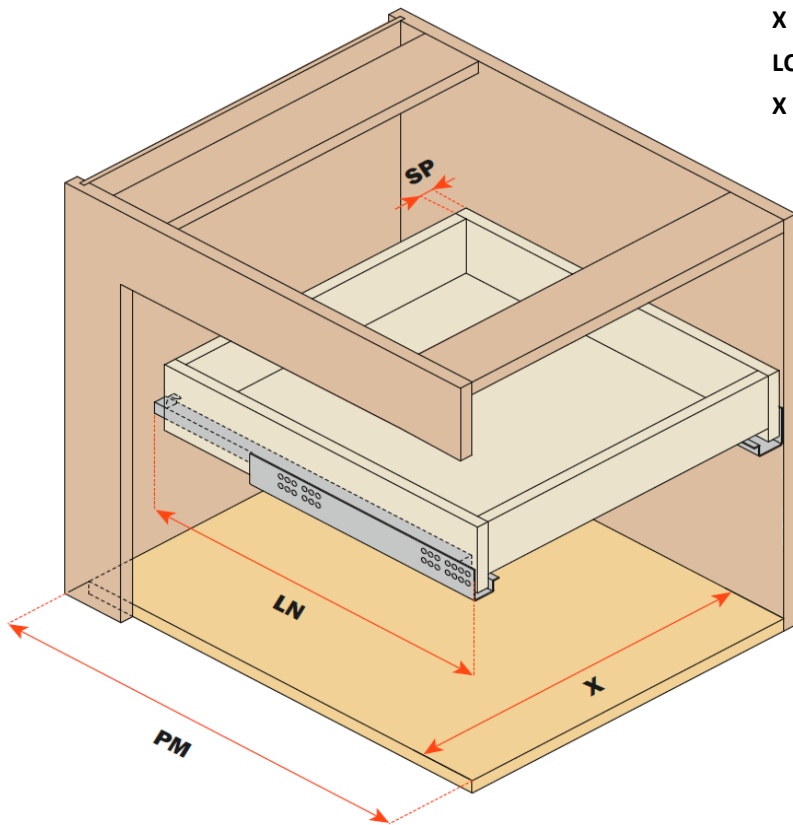

Bohrungen Schrankkorpus Drill holes cabinet

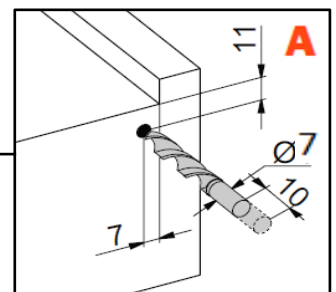
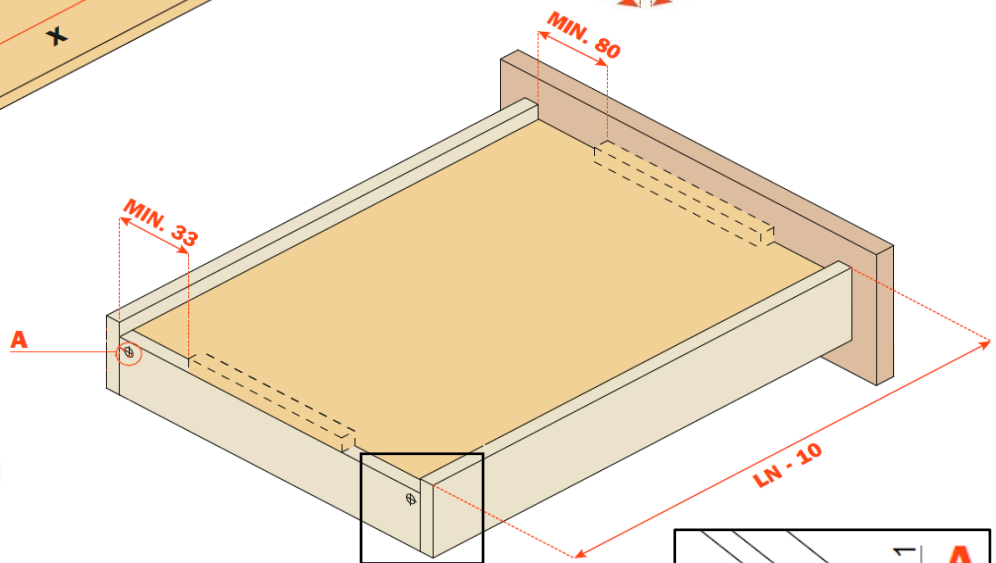
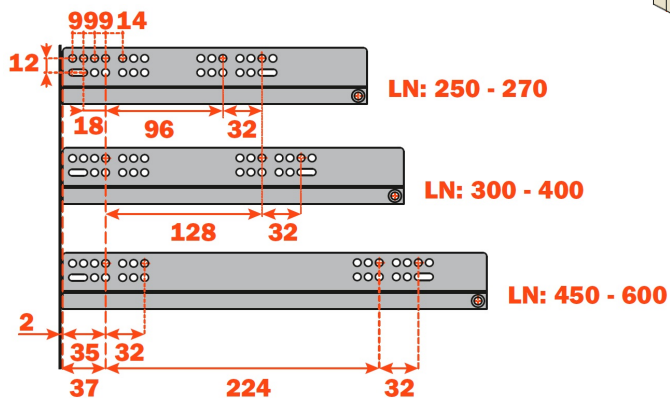

Montage der Kupplungen
Mounting the clips

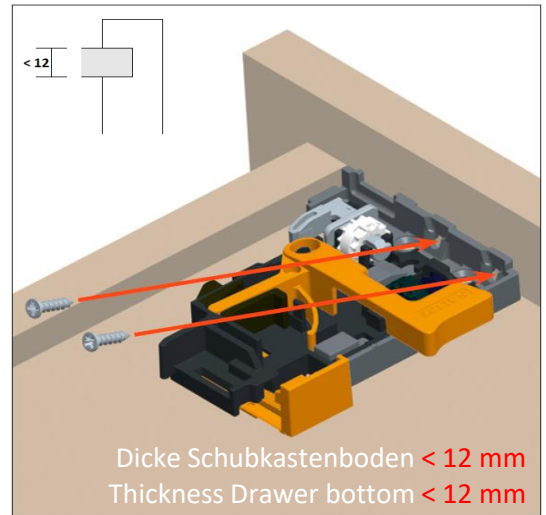
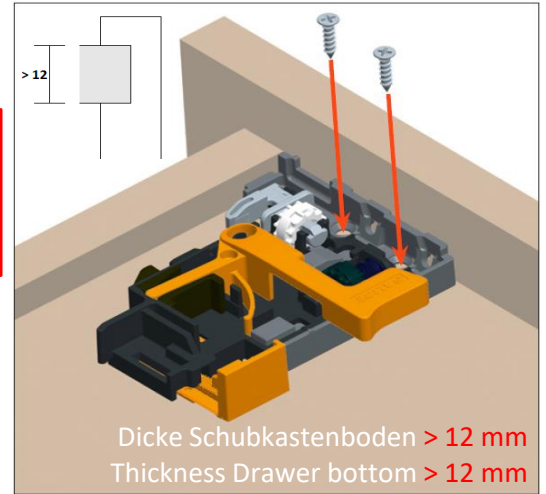
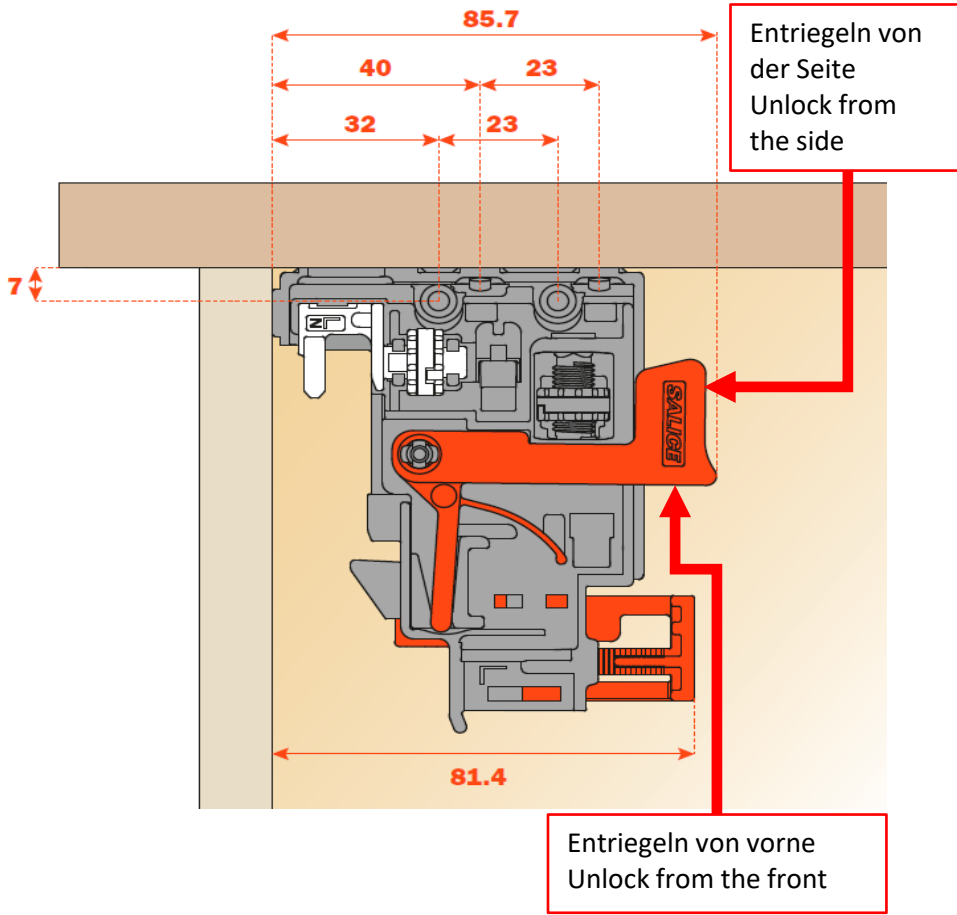

Höhenverstellung + 2,5 mm
Height adjustment + 2,5 mm

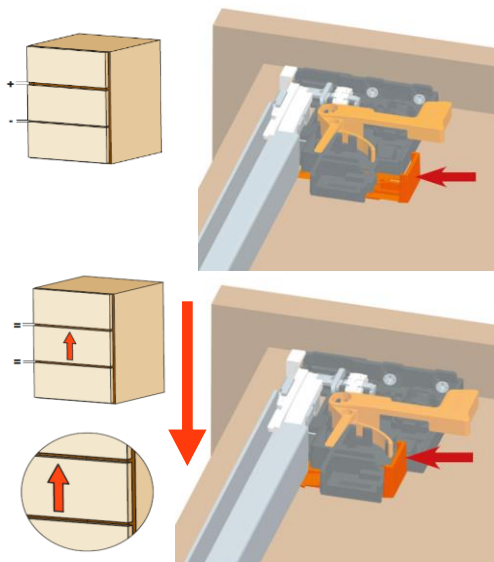

Seitenverstellung ± 1,5 mm
Side adjustment ± 1,5 mm

Die Seitenjustierung bei beiden Clips synchron in die selbe Richtung durchführen!
 Side adjustment of both clips synchronously in the same direction!

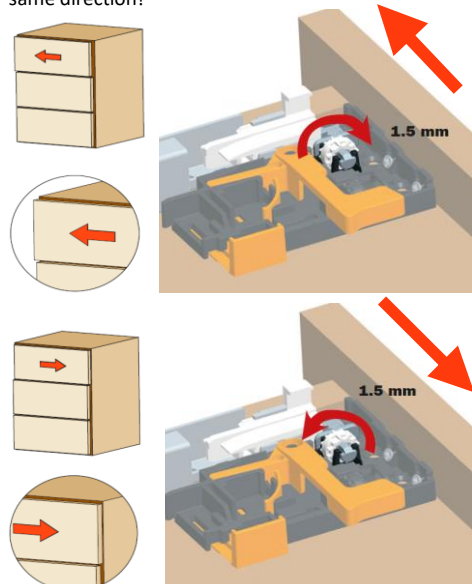

Tiefenverstellung ± 2 mm
Depth adjustment ± 2 mm

